



Software for Monitoring & Control



VTS 10 HMI Software with VTScada SCADA Software Tools Layer

Easy, Open and Powerful software interface designed for operational, maintenance and management needs in mission-critical applications.

Any line manager will tell you that process uptime is the highest priority. Availability of process data is a close second. We designed VTS with these needs in mind. VTS provides users with a reliable, feature-rich, flexible interface designed for mission-critical environments. VTS has 25 years of proven installations in industries such as water & wastewater, manufacturing, power, oil & gas, chemical, food & beverage, air traffic control and broadcasting.

Integrated SCADA tools

VTS includes an integrated SCADA tools layer called VTScada™. Designed specifically for industries such as water & wastewater and gas & power distribution, VTScada provides unparalleled polling management for telemetry applications. Industry-specific reporting tools help you create efficiencies and lower your cost of ownership.

Fast enough for next generation SCADA systems

Unique event-driven execution allows VTS to start a million-tag application on a single laptop less than four minutes. This, combined with support for Windows 7 and 64-bit systems (since VTS 9.0), makes VTS perfectly suited for the next generation of applications.



Toll Free 1-800-463-2783
www.trihedral.com



Contact



+57(1) 284 6932 - 284 6940
www.andeswireless.com
BOGOTA, COLOMBIA



New Configuration Tools for System Integrators

Version 10 includes a suite of new features designed to help system integrators increase productivity by reducing development time, expanding their available services and making it easier to provide technical support when needed.

Clone Applications

Rather than starting every new application from scratch, integrators can build upon a clone of an existing fully-featured system.

Off-line Development

Integrators can create and update applications anywhere their laptops can go.

Multiple developers can work on the same system at the same time and then merge their work without fear of conflict.

New and updated applications can be deployed across multiple servers with a single 'change set' file.

'Change set' files can be easily delivered via email, memory stick, CD or FTP site and imported by end users with limited technical knowledge.

Off-site Back Up

'Change sets' also allow integrators and end users to easily backup configuration information and save it offsite.

On-line Development

Despite the impressive startup and shut down time of VTS, shutting down the HMI should be avoided whenever possible.

Version 10 allows users to reload changes to tag configuration without restarting the application.

Many off-line changes to source code and properties can also be imported without restart.

Address Customer Issues Quickly

If a customer reports an issue with a particular configuration, integrators can quickly return them to a previous known good version.

They can then track down the issue by searching the audit log of all configuration changes for every computer in the system since installation.

More Value Adding Services

Version 10 includes an integrated simple HTTP server that allows developers to display HTML files such as Google™ map pages within display pages.





VTS HMI Software Features

VTS is Windows-based, software for monitoring and control of mission critical applications. VTS applications range from OEM machine interfaces and standalone workstation to large, distributed client/server systems.

Networking and Redundancy

Easily set up automatic fail-over for:

- > VTS Servers
- > VTS Internet (thin) Clients *
- > Redundant connections to physical I/O

Each (thick) VTS user interface can be configured as a redundant server

Configure unlimited backup servers for most services

Supports load sharing across servers

Monitor and alarm computer resources such as hard drive space and CPU usage

Integrated network (TCP/IP socket) connectivity monitoring and alarming

Driver Multiplexer provides seamless failover to redundant connections to I/O

Configuration Management

Reduce integration time by cloning existing applications

Create new applications and update existing ones offsite and offline

Distribute new or updated applications to multiple computers with a single 'change set' file

Use 'change set' files to easily backup and restore configuration information

Easily distribute 'change set' files via email, memory stick, CD or FTP

See audit log of configuration changes for every computer in the system

Return to any previously known good version of the application

Load tag changes without application restart

Load many changes to source code and properties without application restart

Graphics

3500+ graphic symbol library allows unlimited expansion

Photo real meters, clocks and compasses

Group or ungroup complex objects from multiple graphics and tags

Supports background graphics (e.g. maps, watermarks)

Import BMP, JPG, WMF and EMF

3D graphics support **

Displays

Online development

Switch between runtime and development environment without changing views

Supports unlimited display pages

Automatically generated page menu (user editable)

Integrated page navigation tools (i.e. menus, open page buttons, forward and back buttons)

Dual and quad monitor support

Alarm and Event Management

Default alarm management screen integrated into each application

Blinking link to alarm page is visible from all application displays

Sort alarms by date/time and filter by functional area or priority

Number of alarms saved automatically set to 10,000, expandable to unlimited

Events list time-stamps all alarms, security actions, operational changes, dialer activity and other events

Acknowledge alarms locally, by phone using the VTS Alarm Dialer* or via WAP *

Unlimited number of alarm priorities

Printable alarms & events lists

Pop-up dialogs for high priority alarms

Integrated Alarm Dialer

Distributes alarms via email, pagers and text-to-voice. Users may acknowledge alarms during text-to-voice calls

Rosters of up to 30 contacts can be configured for entire application or for specific functional areas

No limit to number of rosters

Dial-in for text-to-voice status or alarm acknowledgement

Shares tag database and alarms database with VTS application

Application Management

Develop and run on Windows OS

Object-oriented structure facilitates application-wide changes

Upgrade to new VTS versions without altering application

Application Security

Flexible privilege-based user accounts

Limit user access to displays and operational control

Application security extends to alarm dialer, Internet server and WAP server

Add, delete, copy or modify accounts

Ensure passwords exceed a minimum, length contain alphabetic, numeric or special characters or expire

Security changes are immediate and system wide

Supports SSL (secure socket layer)

User-definable automatic timed logout

Supports SMTP email servers requiring Transport Layer Security (e.g. Gmail™) when sending alarm notifications

Support for USB dongles

Integrated Report Generation

Supports scheduled or ad-hoc reports

Output reports to screen, printer, file, database, email, Microsoft Excel™ or Excel template files

VTS ODBC Server allows direct calls to the VTS historical databases from 3rd party reporting packages like Crystal Reports and Excel

Report pages are time zone aware

Historical Data Logging

Log on time or change

Log to native format or external database

* The VTS Alarm Dialer & VTS Internet Client/Server and WAP are optional components. These can be added to any Runtime or Full-Development license.

** 3D graphics must be saved in 2D format (i.e. bmp, jpg). 3D graphics created with 3rd party products may be incorporated into VTS graphics library.



VTS Features (Con't)

Logging configurable by tag

Native binary format database provides compact storage and high-speed application access

Historical Data Viewer (HDV)

Integrated HDV displays historical and real-time data in graph or tabular format

Display unlimited analog or digital trend values simultaneously

Adjust pen sizes, weights, and colors

Display min, max, average values

Supports logarithmic scaling

Export data to file or database

Save trend groups for later recall

Attach operator notes to trends

Easily open the HDV pre-loaded with tag values for defined periods

Add labels to HDV graphs showing tag values at selected points in time

Remote Access (Internet, WAP, Dial-in)

VTS Internet Server* pushes data to Internet clients via an ActiveX downloadable plug-in. All displays automatically converted for use by Internet Client

Dial-in using VTS Alarm Dialer* for status, control and alarm acknowledgement

Optional Wireless Application Protocol Server supports custom pages for status, control and alarm acknowledgement via wireless devices like the Blackberry™

WAP Server supports GZIP Encoding

3rd Party Application Support and External Data Analysis

Report generator or trend screen can output data to standard office products, such as Excel and Access (e.g. CSV)

SQL tags log data to Oracle, SQL, MySQL and Access databases on time, event or change of value

Spawn 3rd party programs

Supports SQL calls to VTS historical data

Driver support for 3rd party products (e.g. Pi, Excel via DDE)

I/O Connectivity (Device Drivers)

Support for over 100 industry standard protocols (e.g. Modbus, AB, Siemens)

Includes Siemens S7 Ethernet and DNP3 drivers

Modem Discriminator allows DNP3 driver to receive remote dial-up phone calls

Supports some proprietary I/O protocols

New drivers created to meet client needs

OPC client support

DDE support

Modbus master/slave support

Integrated IANA™ registered TCP/IP port

Integrated SNMP driver uses UDP-based network protocol to communicate with devices used in oil & gas and broadcasting

DataRadio Diagnostic driver supports ViPR™ and Phantom™ radios

Tag Database

Supports unlimited number of tags

Create and replicate tags outside of VTS using Access, Excel and SQL Server

All resources (e.g. modems, I/O, device drivers) are treated as tags, facilitating easy application development

Test without live I/O using manual input values

Quality indicators on input tags

New I/O tags automatically flagged as 'Questionable' to assist commissioning

Analog tags support deadband and delay when displaying change or triggering alarms

Allows addition of new parameters to existing tags

Configuration Toolbox

Configure displays, navigation menu and tag database from one interface

Easy-to-use graphic origination tools

Simple click and drag development tools (e.g. bitmap library, polygons and tag-driven animations)

Libraries allow fast development of custom reports, modem/alarm displays

Operator Notes

Electronic log of operator notes

Networked to allow all authorized users remote and local access

Notes include timestamp, user name

Encrypted to eliminate tampering

Print range of date/times or all notes

Display notes by date

Ease-of-use & Reliability Features

Leave messages for operators using highly-visible sticky notes

Create your own custom tooltips

Acknowledge alarms while configuring application

Quickly configure the alarm tags built into Analog Status and Digital Status Tags

Rate-of-change object watches for rapid changes in values that indicate expensive leaks and spills

Multi-write object sets values for up to 50 outputs with a single operator action (Useful when starting HMI or replacing PLCs)

Trigger object initiates system events based on time or changes in values

Use History Statistics Tag to display calculated values (e.g. Compare last week's average flow rate to current rate.)

Display numeric values in Decimal, Hexadecimal, Octal or Binary format

Configure VTS to shutdown when Universal Power Supply runs low



VTS Features (Con't)

Configure alarms to rearm after a defined period once they have been acknowledged

All alarm dialer roster activations now recorded as events in the alarm history

Integrated simple HTTP server displays HTML files such as Google™ map pages

Remote (Online) Configuration

Online configuration of tags and graphics displays without interrupting monitoring and control functionality

Automatic update of all local and remote application computers without stopping application

Edit/Lockout manager allows multiple users to configure an application simultaneously

Supports update, rollback and administrator override for changes

Tag configuration capability over VTS Internet Clients

Web Services

SOAP (XML) interface allows 3rd party business systems to make direct calls to real-time and VTS historical data

Supports SQL calls from 3rd-party applications to VTS native database

Supports SELECT commands and WHERE clauses

Calls can include requests for data from a time/date range (e.g. min, max, time of min, time of max, ave, total, number of rising or falling edge transitions)

Soft Logic Control

Deadband tag can be used as datasource for output controls (includes delay and hysteresis)

Calculation tag (includes mathematical and logical functions) can be used as datasource for output controls

Expression tag supports complex scripting logic to be used as datasource for output controls

Modem Management

Supports modem pooling across servers for improved resource efficiency

Includes custom Unimodem driver

Data and VTS Alarm Dialer requests are automatically routed to appropriate voice and data modem(s). No configuration necessary

Supports dedicated modems for functional application areas

Supports logging of modem activities

Graphics show modem events, usage statistics and modem status

Advanced Customization

Object-oriented VTS scripting language (similar to C++ in syntax and functionality) allows unlimited customization

Most features of product can be customized as necessary

Supports reusable objects (e.g. scripts, graphics, custom displays, library objects) to reduce development time

Support direct copying of graphics from application pages to text editor, for edit and copy back into application

Create and modify custom tag types

Parent tags support unlimited child tags to reduce errors and development time

Background scripts can run as services to perform scheduled tasks or watch for specific occurrences (e.g. run certain tasks when a user logs in)

Priority services can be set to run before the application is started

Hardware/OS Minimum Requirements*

Windows 7 (32-bit or 64-bit), Vista (32-bit or 64-bit), XP, 2008 Server or 2003 Server operating systems

2 GHz processor and 2 Gb of RAM

Hard disk with 20 Gb of free space

SVGA graphics card for XP, DirectX 9 compatible graphic card with at least 32 Mb of graphics memory for Vista

CD-ROM or DVD-ROM drive (Only if installing from a disc)

Mouse, pointing device or touch screen

Debugging Tools

Debugging tools available locally or remotely through VTS Internet Server*

Automated application tests available

Source code debugger for script

Tracing of all VTS activities

View error statistics and sent/received communications for device drivers

Source debugger can highlight what code has been run or tested to date

Help Files and Support

Support provided by trained engineers and computer scientists

Provided by phone (toll free in North America) and email

Searchable integrated help manuals for operators, developers and programmers

24/7 support contracts available

Training**

Courses available at our Bedford and Orlando training facilities or on-site anywhere in North America upon request

Operation & Configuration: For integrators, OEMs, consultants, operators, maintenance & IT staff

Advanced Scripting: For advanced system integrators and OEM users

Custom courses can be created based upon specific user requirements

* Actual hardware/OS requirements based upon application architecture

** Contact Trihedral for course scheduling and prices.



VTScada Software Layer Features

In addition to the features listed on the previous pages, the VTScada software layer adds features for use in telemetry applications, specifically in the water and wastewater industry. These features are intended to decrease integration time and application complexity.

I/O Drivers

- Special VTScada polling driver allows polling to be grouped and scheduled for polling cycle efficiency
- Protocols to industry standard RTUs available
- Protocols to some proprietary RTUs available
- Includes diagnostic drivers for MDS and DataRadio radios
- Allen-Bradley driver supports Radio Keying
- Some drivers incorporate store and forward and logged data retrieval capabilities

Industry Specific Reports

- Preconfigured reports for water and wastewater included

Graphics and Displays

- A simple graphics screen is automatically generated for each RTU and the display is populated with all associated I/O and alarms
- Graphics for RTU sites change color depending upon the status of polling communications and the status of the associated I/O

High Efficiency Tag Development

- Special analog and digital tag types integrate alarming and logging capability to reduce application development time
- Pump status tags automatically associate with preconfigured pump status reports, displaying pump runtimes and starts/stops

Polling Management

- Automatically manages scheduled polling cycles for remote telemetry units (RTUs)
- Unlimited number of independent polling groups
- 'Fast poll' capability allows you to set a higher polling frequency for specific RTU sites to facilitate maintenance
- Use external triggers to poll on infrequent schedules or in response to operator commands
- Polling may be disabled/enabled in any polling driver

Historical Data Logging

- Robust high-performance data logging and historical synchronization across networks
- Ability to log to SQL databases like My SQL, SQL Server and Oracle
- Distribute multiple historians to spread load across multiple servers
- Historical data are separated into monthly folders for easy archiving

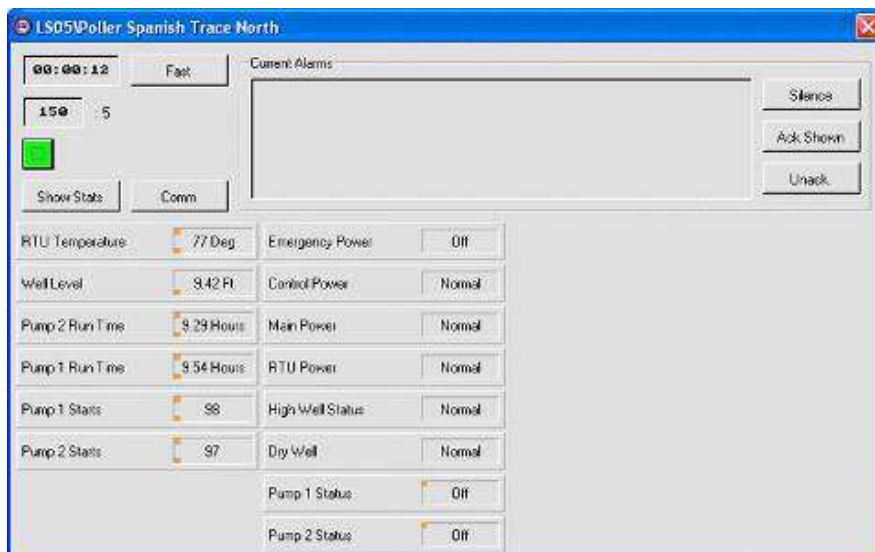

Automatically Generated Site Display

The automatically generated site display includes a list of all analog inputs, digital inputs and digital outputs associated with the site's polling driver tag.

Additionally, an alarms list, data age indicator, site status indicator and fast/normal polling selector make this simple display very useful.

This feature was added to reduce development time and reduce the likelihood of errors during system integration.

Custom site displays may also be created as desired.



Typical HMI Displays

Each application automatically includes a default set of displays, as described below.

Process Displays

Process displays are application specific and provide an operational interface for monitoring and control activities.

Process displays include graphical overviews of the process in a full-screen or windowed (user-selectable) view.

Such displays are developed using objects from the graphics library, tag animations, polygons, etc.

A series of process displays is often connected via hotboxes (hyperlinks to other displays). These hotboxes allow displays to be developed in a logical order.

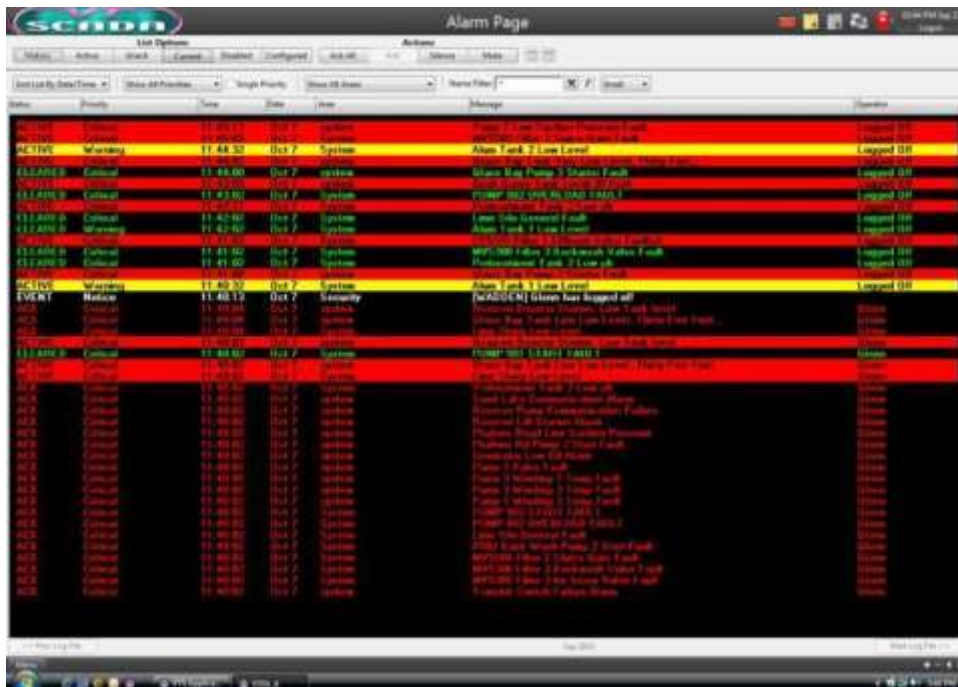
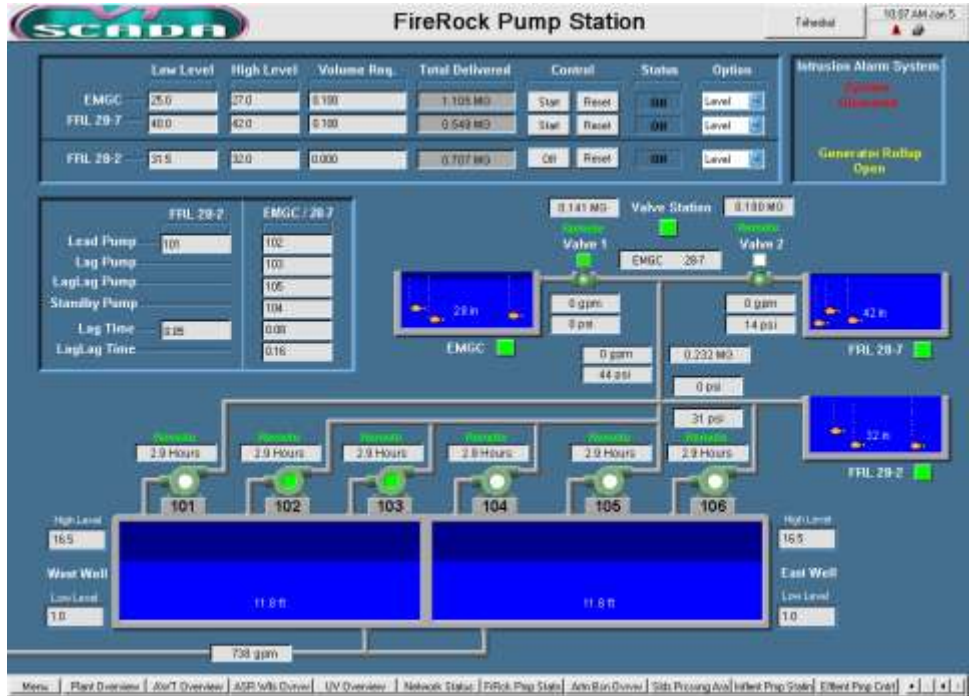

Alarm Manager

The VTS Alarm Manager includes lists of Current, Active, Unacknowledged, Disabled, and Configured alarms. This is the primary interface for viewing and managing alarms, although additional alarms lists may be included on process displays as necessary.

Additionally, a history list includes all alarm and event history. Events include information such as security logon activity, VTS Alarm Dialer activity, operational setpoint changes, etc.

Any range of dates may be selected for alarm history printing.



Typical HMI Displays (Cont'd)

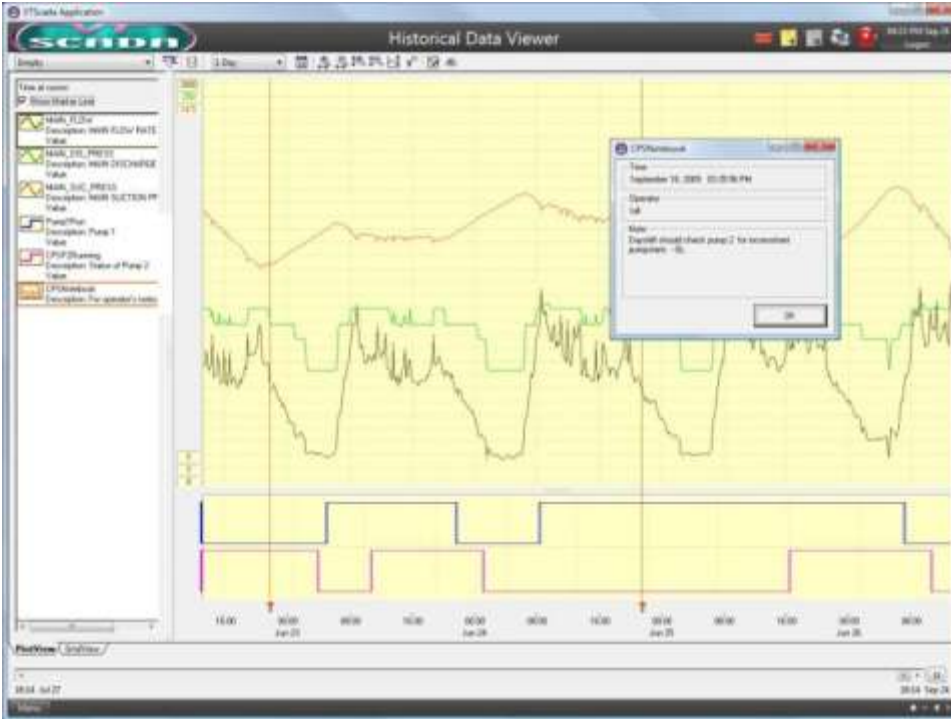

Historical Data Viewer

The Historical Data Viewer (HDV) combines historical data logs with real-time data to display a continuous picture of any number of application variables over time.

Both analog and digital data are displayed simultaneously. Pens can be removed or added as necessary and groups can be saved for later recall.

The attributes (e.g. color, thickness) or any pen can be adjusted independently.

Data are displayed in either trend view or tabular format and encrypted operator notes may be added to specific points in time.

Data may be exported to a database or to CSV files for external analysis.

Report Generator

The Report Generator has two components, an ad-hoc report developer and a report tag that can be scheduled to trigger a pre-defined report.

Report tags can be triggered to generate a report daily, weekly, monthly, on event or manually.

VTScada includes a set of pre-defined generic reports to meet the needs of the water and wastewater industry.

Additional custom reports can be added as required.

Report output can be sent to screen, file, Excel spreadsheet, Excel Template, database or as an email attachment.

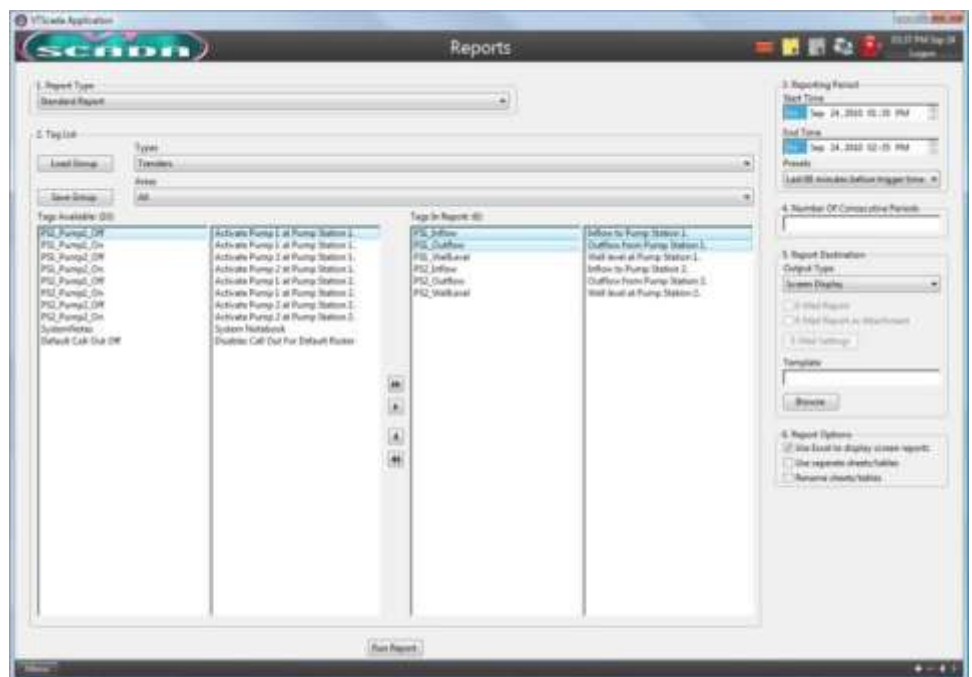



VTS Components & Extensibility

This diagram displays integrated components of VTS and a variety of interfaces available to extend the capabilities of any VTS application.

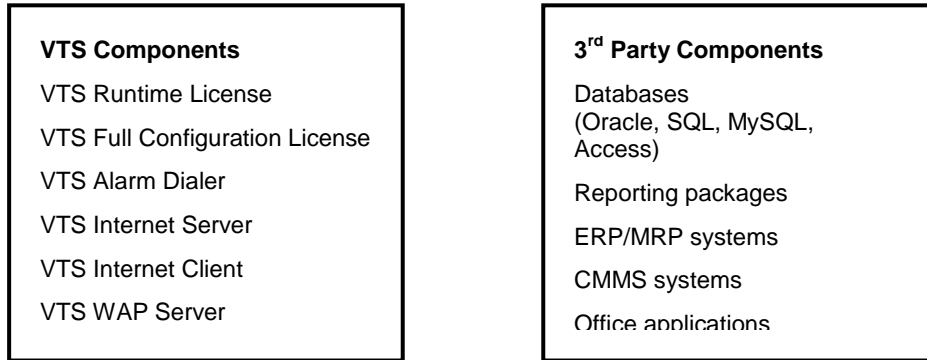

Simple overview of VTS application extensibility to include 3rd party applications and I/O devices

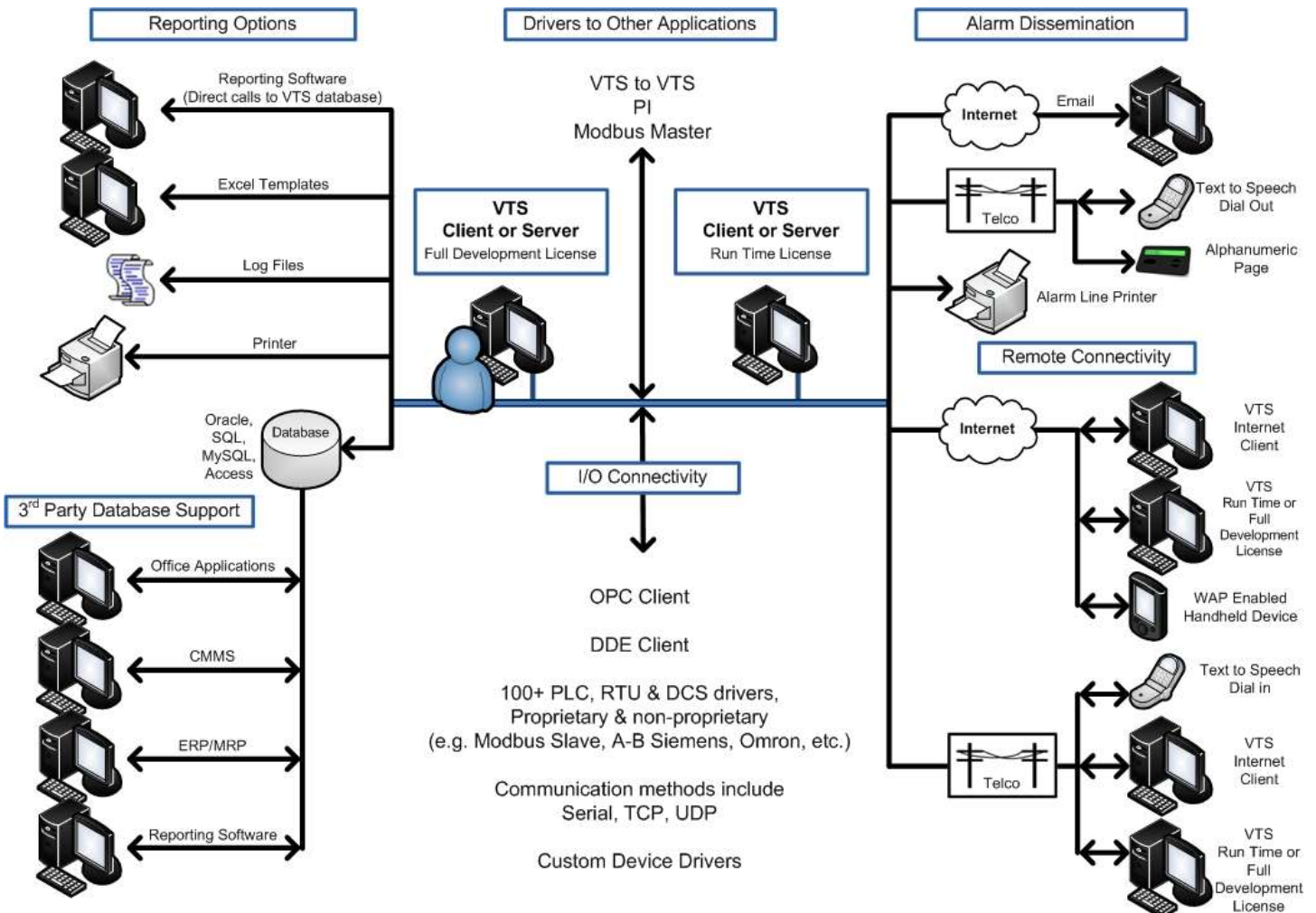



Distributed Application Management

To ensure system uptime and reliability in the event of computer hardware failure, VTS maintains synchronized copies of the entire application on up to 64 VTS server computers.

Copies of all tag database, application security, display, script, menu and networked variable files are maintained on each server, allowing any backup server to automatically assume server responsibilities without service interruption.

Historical and alarm history data can be synchronized across two servers to protect against data loss.

Application change management is controlled by a single central server, which handles locking and updating of files, ensuring application changes made from any computer are synchronized across all networked clients and servers.

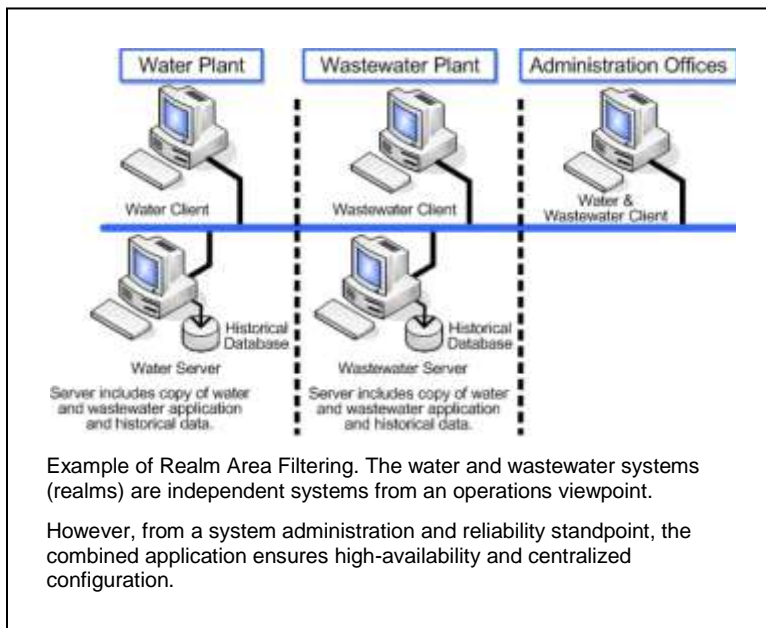
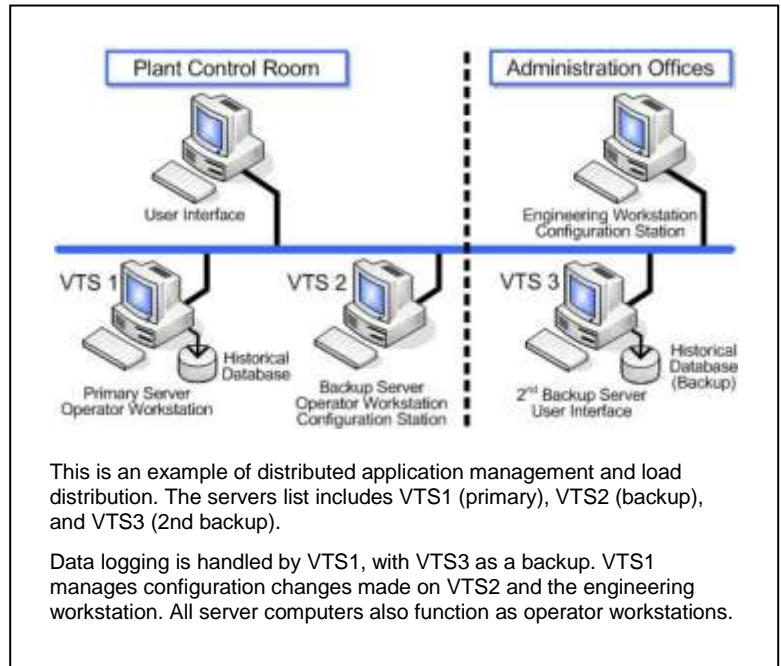

Realm Area Filtering

By combining Realm Area Filtering with Distributed Application Management, related applications are combined into a high-availability centralized system.

Each server computer maintains a copy of the entire application, including tags, security, displays, etc. from each of the related systems (realms).

Application displays and data access are dependent upon the user logging into the computer. For example, a water plant user will only see water (realm) system data and displays, but 'super user' logins may be configured to show both water (realm) and wastewater (realm) data and to run system-wide reports.

This approach is used to minimize investment in computer infrastructure without losing historical data backup and automatic server failover capabilities. Centralized configuration also allows both systems (realms) to be configured from the same computer.



Licensing Options

VTS and the VTScada telemetry tools layer are bundled together as a single package. Thus, when VTS is installed, VTScada is also installed. No additional license is required.

Optional Components

The VTS Internet Client/Server, VTS Alarm Dialer, VTS Web Services, VTS OPC, VTS ODBC, VTS WAP options must be purchased as optional components of a VTS (VTScada) Full Development or VTS (VTScada) Runtime license.

VTS (VTScada) Full Development

Used for application configuration activities

Can be used as an operator interface.
Allows operational changes

Allows access to administration activities (e.g. security management)

Can be used simultaneously as a client and as a primary or backup server

Licensing is per seat

VTS (VTScada) Runtime

Does not allow application configuration activities

Can be used as an operator interface.
Allows operational changes

Allows access to administration activities (e.g. security management)

Can be used simultaneously as a client and as a primary or backup server

Licensing is per seat

VTS Alarm Dialer

Distributes alarms via phone (using text-to-voice), email and alphanumeric pager

Allows incoming calls to check status and to acknowledge alarms

Add-on to VTS Full Development or VTS Runtime license

VTS Web Services

Allows 3rd-party business applications to retrieve data from the VTS historical database and use selected VTS services

Examples include delivery scheduling systems that require calculations by VTS to predict when deliveries are required

VTS interprets requests, performs requested actions, and responds in the requested format

Requires understanding of XML, SOAP, and VTS programming techniques

VTS Internet Server (includes one VTS Internet Client License)

Permits (thin) Internet/Intranet clients access to VTS applications

Does not require additional Internet server software (e.g. IIS, Apache)

Includes one VTS Internet Client

Displays sent to clients are automatically created and are identical to thick client displays

Add-on to VTS Full Development or VTS Runtime license

VTS Internet Client

Thin Internet/Intranet clients used to access VTS applications

Pages served through ActiveX component downloaded from VTS Internet Server

Allows all operational monitoring and control activities and limited configuration activities

Allows IP connection over dialup or Ethernet

Licenses are concurrent

Add-on to VTS Full Development or VTS Runtime license

VTS WAP Server

Remotely monitor system status and acknowledge alarms using WAP enabled devices like the Blackberry™, Pocket PC™, and Palm™

Users require a wireless account.
Server requires a dedicated IP address

Compatible networks include DECT, DataTAC, Mobitex, iDEN, GRPS, CDPD, CDMA, GSM, PDC, PHS, TDMA, FLEX, ReFLEX, and TETRA

Access governed by VTS security manager

VTS OEM/System Integrator Package

Available to OEMs, and system integrators only

Used to develop and test application before distribution at a customer's site

Includes all capabilities of VTS Full Development, VTS Runtime, VTS Internet Server, VTS Internet Client and VTS Alarm Dialer

Allows continuous use for 24 hours.
Application must then be restarted

Purchase includes training for 2 users

Not for resale to end-user customers

VTS ODBC Server

Allows reporting software like Crystal Reports™, XL Reporter™, Microsoft Access™ or Microsoft Excel™ to extract logged system information directly from VTS applications

VTS can be queried as if it were a database of timestamps and values

Reporting computers need not have VTS installed

Add-on to VTS Full Development or VTS Runtime license

VTS OPC Server/Client

Server allows OPC-compliant programs (including VTS applications with OPC clients) to send and receive live process data to and from VTS applications

Client allows VTS applications to send and receive live process data to and from an OPC-compliant server (including VTS applications with configured OPC servers)

Client available at no additional cost
Server requires additional license fee



Tag Count Options

Licenses are purchased based upon the number of tags required by the application. Drivers, I/O, totalizers, alarms, modems, fonts, rosters and many other objects are represented by tags.

Therefore, determining the number of tags accurately requires an understanding of the system architecture.

Intro (Up to 200 tags)

Typical applications include very small installations with few I/O

Bronze (201-1000 tags)

Typical applications include small installations with relatively low I/O counts

Silver (1,001 – 10,000 tags)

Typical applications include midsize installations with one or more applications combined

Gold (10,000+ tags)

Typical applications include large installations with multiple applications combined into one system

Note: Tag counts can be easily upgraded (e.g. from Bronze to Silver) by installing a new software license key.

Customer Testimonials

This is what our customers are saying about VTS and VTScada.

- ▶ *"We are so pleased with VTS. It has exceeded our expectations in every way."*
Shawn Derrington, IT Director & Microsoft Certified Systems Engineer, Georgetown Municipal Water & Sewer, KY
- ▶ *"The system has greatly improved the District's reaction time and management capabilities during emergency situations."*
David L. Moore, Executive Director, Southwest Florida Water Management District
- ▶ *"The automated plant is today more reliable, and the operators are able to make better production decisions."*
William Duncan, Instrument & Control Supervisor, Moosehead Breweries Ltd., NS
- ▶ *"As long as Trihedral keeps offering this level of customer support, there will always be VTScada at Gainesville."*
Thomas Wallace, Gainesville Regional Utilities
- ▶ *"The technical support at Trihedral is second to none. They get to the heart of the problem from almost anywhere. That's the truth."*
Mark Russo, Fountain Hills Sanitation District
- ▶ *"From our first phone call requesting help, they took total ownership of my problem, made it theirs, and engineered a solution. They worked as if they were part of my staff working towards the common goal of providing my customer with a quality product."*
Craig C. Corzine, CSE Engineering Inc.
- ▶ *"I can't speak highly enough about the support I received from everybody at Trihedral. In the last 29 I can count on one hand the number of companies I have dealt with that offer this level of after-the-sale support. This includes companies with whom I have spent a million dollars. That's pretty impressive."*
David Kanoy, Kanoy & Kanoy Inc.
- ▶ *"[Trihedral's] support is phenomenal. It was great to be able to just call and get a person. There were not a lot of hoops to jump through. That helped to push us towards using VTScada."*
Devin Carroll VP of Custom Controls Unlimited

Contact



+57(1) 284 6932 - 284 6940
www.andeswireless.com
BOGOTA, COLOMBIA